

GIUNTO AD UNA VIA
One-way joint

code	
B 1101	

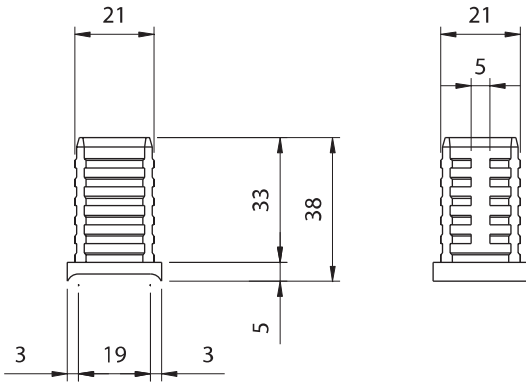

GIUNTO AD UNA VIA
One-way joint

code	
B 1102	

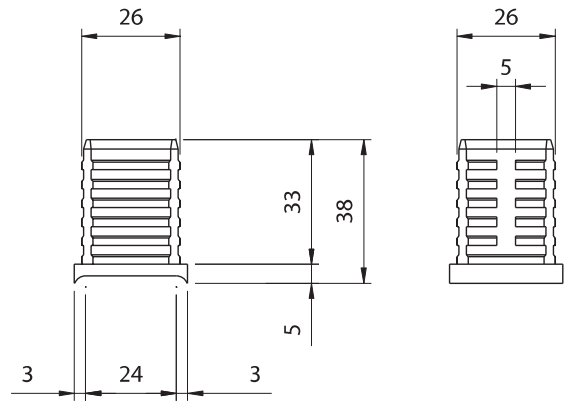

GIUNTO AD UNA VIA
One-way joint

code	
B 1103	

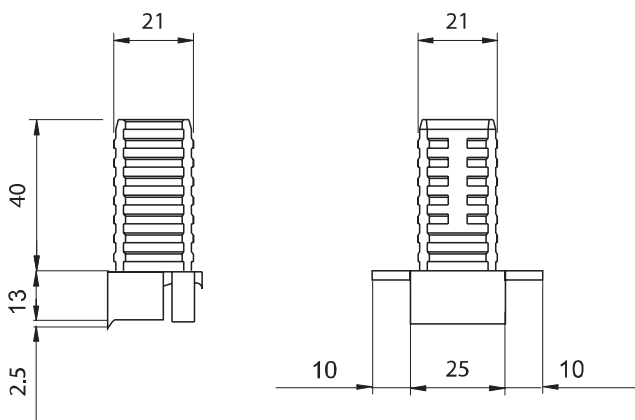

GIUNTO AD UNA VIA
One-way joint

code	
B 1106	

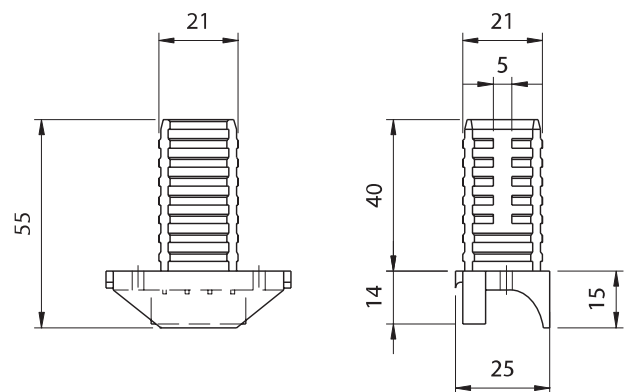

GIUNTO AD UNA VIA
One-way joint

code	
B 1107	

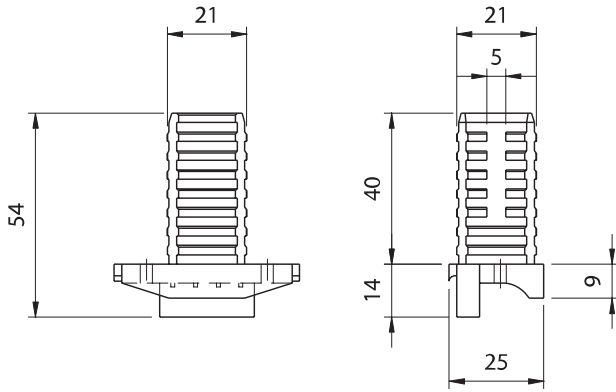

GIUNTO A DUE VIE
Two-way joint

code	
B 1201	

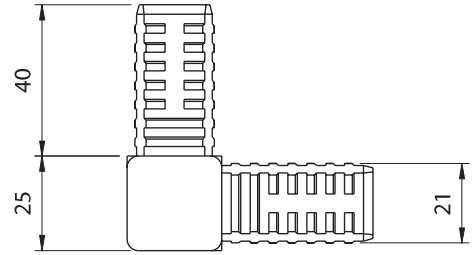

GIUNTO A DUE VIE
Two-way joint

code	
B 1202	

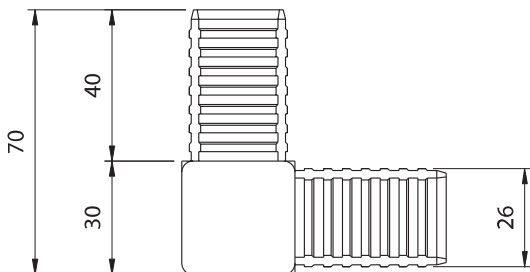

GIUNTO A DUE VIE
Two-way joint

code	
B 1205	

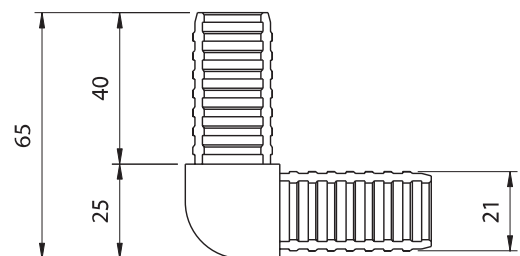

GIUNTO A DUE VIE
Two-way joint

code	
B 1206	

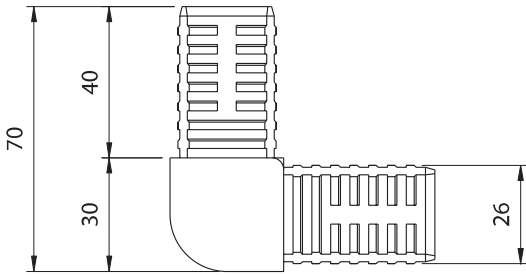

GIUNTO A DUE VIE A 45°
45° Two-way joint

code	
B 1207	

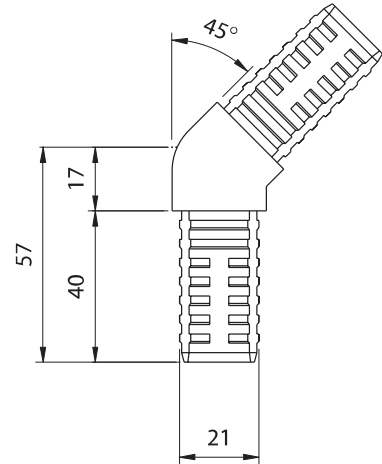

GIUNTO A DUE VIE A 45°
45° Two-way joint

code	
B 1208	

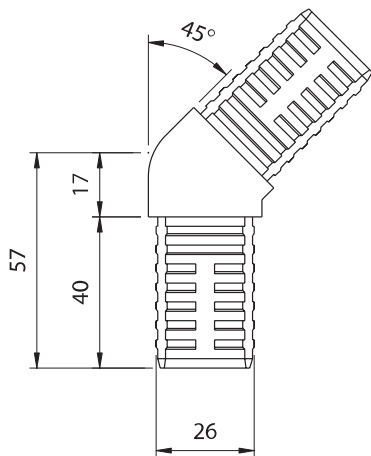

GIUNTO A DUE VIE
Two-way joint

code	
B 1209	

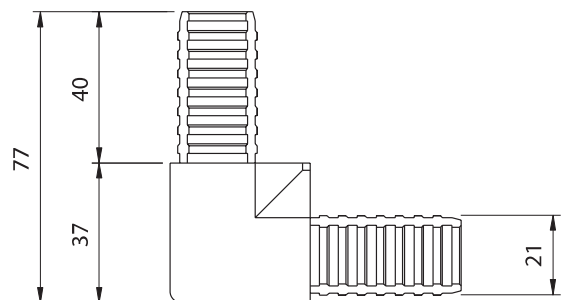

GIUNTO A DUE VIE
Two-way joint

code	
B 1210	

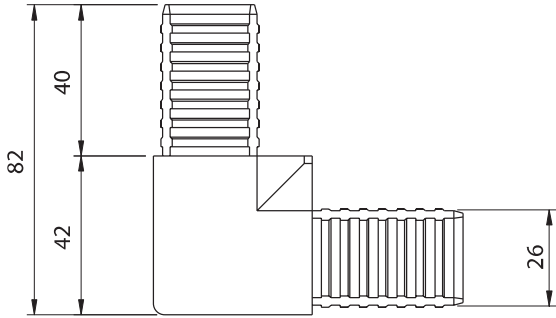

GIUNTO A DUE VIE
Two-way joint

code	
B 1502	

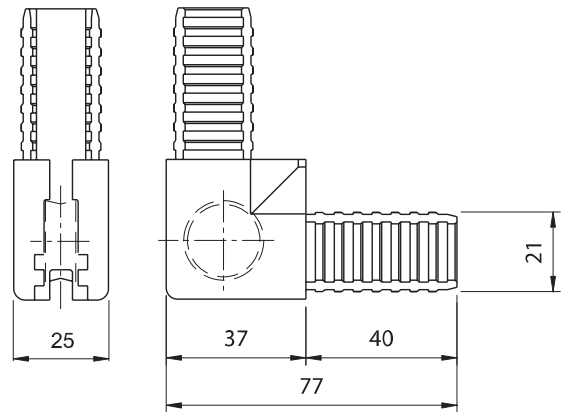

GIUNTO A TRE VIE
Three-way joint

code	
B 1301	

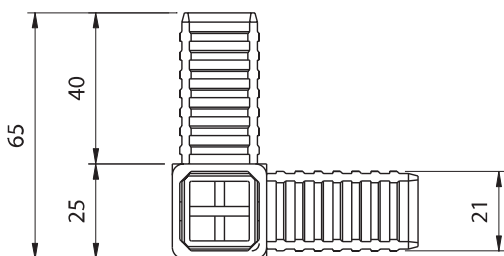

GIUNTO A TRE VIE
Three-way joint

code	
B 1302	

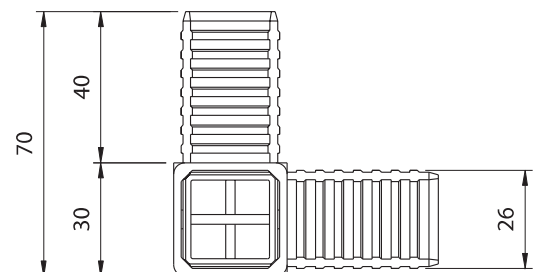

CORNICE PER GIUNTO B 1201
Moulding for B 1201 joint

code	
B 1421	

CORNICE PER GIUNTO B 1202
Moulding for B 1202 joint

code	
B 1422	

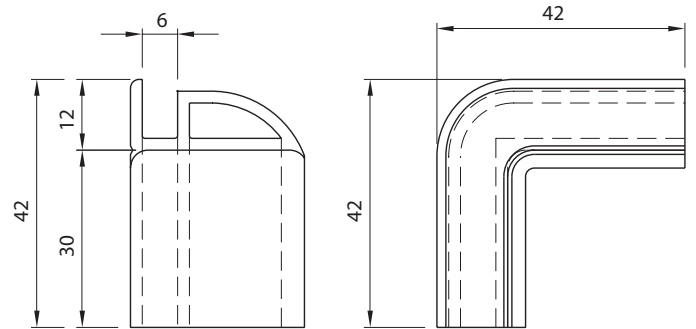
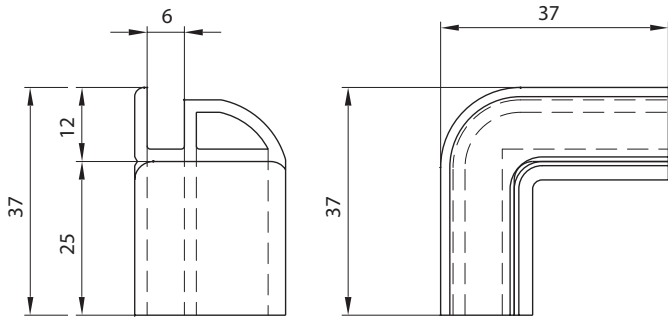

CORNICE A 90° PER GIUNTO B 1205
90° Moulding for B 1205 joint

code	
B 1423	

CORNICE A 90° PER GIUNTO B 1206
90° Moulding for B 1206 joint

code	
B 1424	

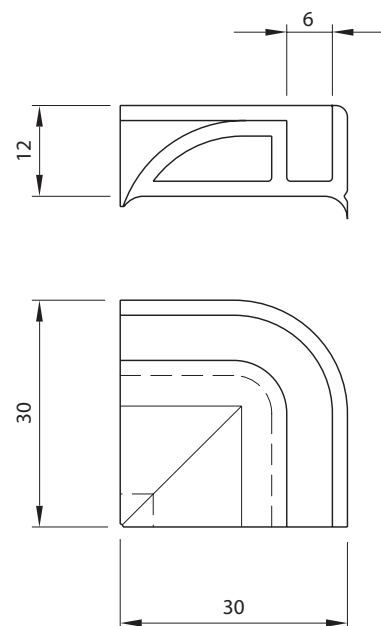
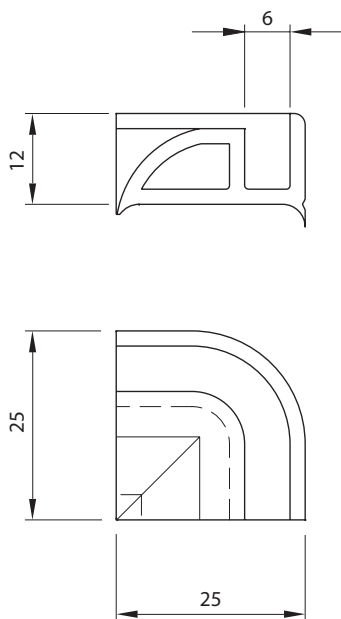

CORNICE A 45° PER GIUNTO B 1207
45° Moulding for B 1207 joint

code	
B 1425	

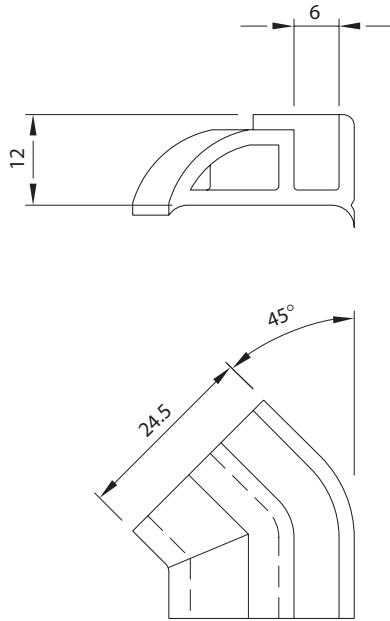

CORNICE A 45° PER GIUNTO B 1208
45° Moulding for B 1208 joint

code	
B 1426	

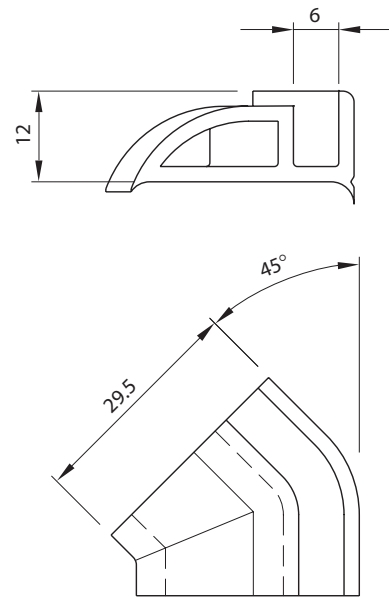

GIUNTO ORIENTABILE Q25 SX
Swivelling joint Q25 LH

code	
B 1601	

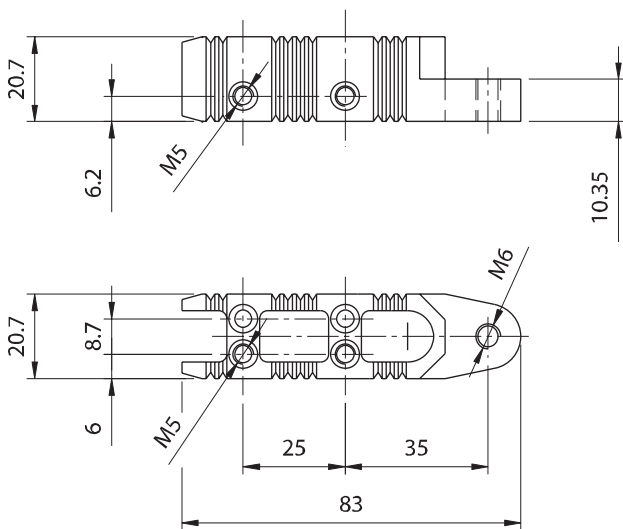

GIUNTO A INCLINAZIONE VARIABILE
DA UTILIZZARE SU PROFILI A SEZIONE
QUADRA mm 25

VARIABLE TILTING JOINT
TO BE USED WITH 25 mm SQUARE
SECTION PROFILE

GIUNTO ORIENTABILE Q25 DX
Swivelling joint Q25 RH

code	
B 1601	

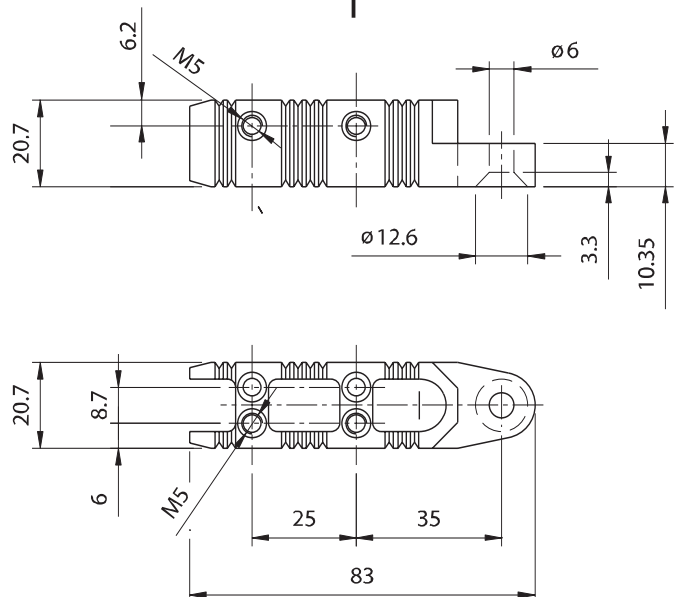

GIUNTO A INCLINAZIONE VARIABILE
DA UTILIZZARE SU PROFILI A SEZIONE
QUADRA mm 25

VARIABLE TILTING JOINT
TO BE USED WITH 25 mm SQUARE
SECTION PROFILE

GIUNTO ORIENTABILE Q30 SX
Swivelling joint Q30 LH

code	
B 1602	

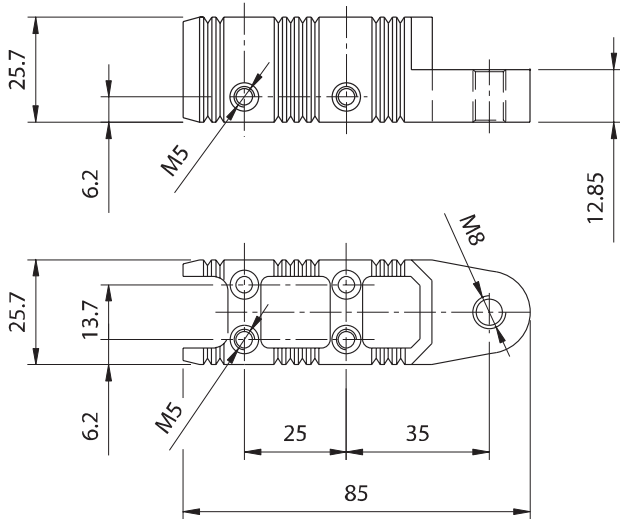

GIUNTO A INCLINAZIONE VARIABILE
DA UTILIZZARE SU PROFILA SEZIONE
QUADRA mm 30
VARIABLE TILTING JOINT
TO BE USED WITH 30 mm SQUARE
SECTION PROFILE

GIUNTO ORIENTABILE Q30 DX
Swivelling joint Q30 RH

code	
B 1602	

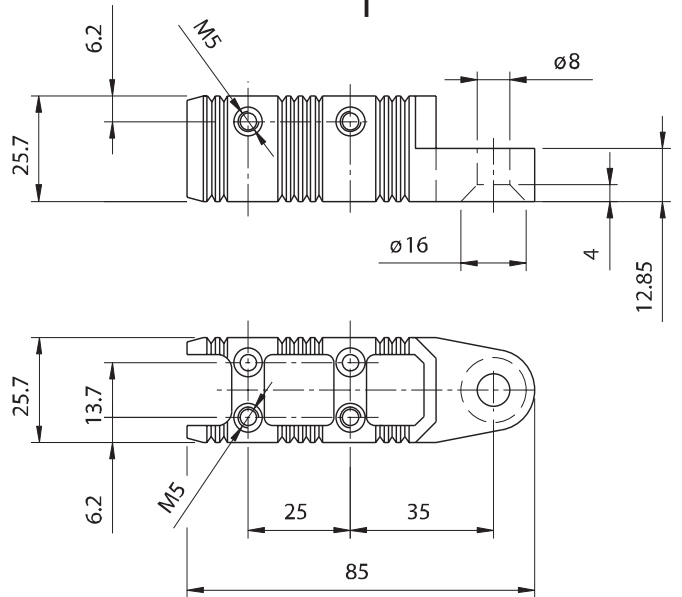

GIUNTO A INCLINAZIONE VARIABILE
DA UTILIZZARE SU PROFILA SEZIONE
QUADRA mm 30
VARIABLE TILTING JOINT
TO BE USED WITH 30 mm SQUARE
SECTION PROFILE

PIASTRINA DI COLLEGAMENTO A 45°
45° Connection plate

code	
B 8001	

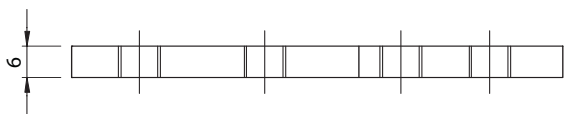
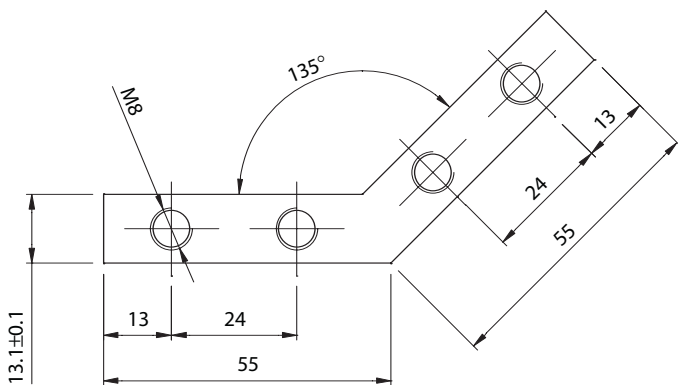

PIASTRINA DI COLLEGAMENTO A 30°
30° Connection plate

code	
B 8008	

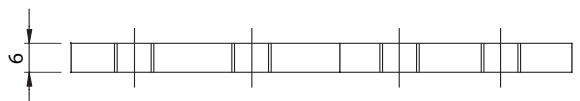
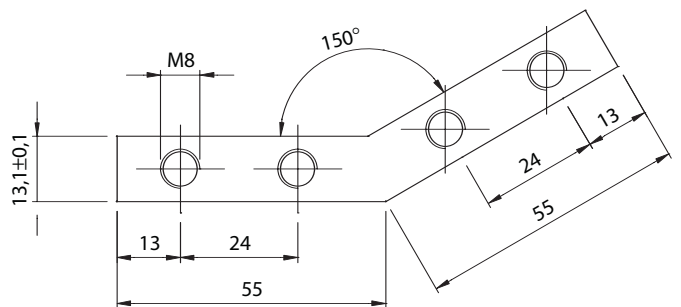

PIASTRINA DI COLLEGAMENTO A 60°
60° Connection plate

code	
B 8013	

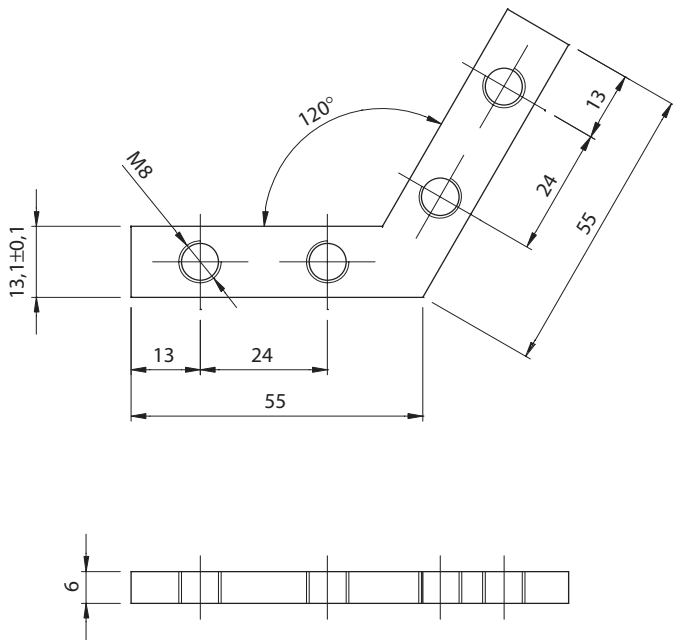

PIASTRINA DI COLLEGAMENTO
Connection plate

code	
B 8014	

